

Nyloc Insert Nut

Thread Type: Metric - Coarse

Thread Direction: Right Hand

Material: Stainless Steel

Class Grade: A4-70 G316

Corrosion Protection Level: Ultimate

Standard: DIN 985

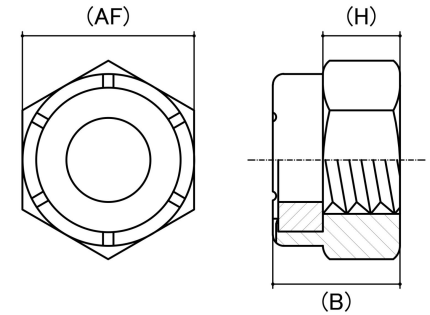

*CAD drawings shown for graphic representation only.**

Size	Thread Pitch (mm)	Thread Type	Overall Nut Height (B) (mm)		Hex Height (H) (mm)	Across Flats (AF) (mm)		Spanner Size (AF) (mm)	sku (qfind)
			Min	Max	Nom	Min	Max		
M2	0.40	Coarse	3.00	3.20	1.80	4.82	5.00	5	41NS2M
M2.5	0.45	Coarse	3.30	3.60	2.00	4.82	5.00	5	41NS25M
M3	0.50	Coarse	3.70	4.00	2.40	5.32	5.50	5.5	41NS3M
M4	0.70	Coarse	4.70	5.00	3.20	6.78	7.00	7	41NS4M
M5	0.80	Coarse	4.70	5.00	3.20	7.78	8.00	8	41NS5M
M6	1.00	Coarse	5.70	6.00	4.00	9.78	10.00	10	41NS6M
M8	1.25	Coarse	7.64	8.00	5.50	12.73	13.00	13	41NS8M
M10	1.50	Coarse	9.64	10.00	6.50	16.73	17.00	17	41NS10M
M12	1.75	Coarse	11.57	12.00	8.00	18.67	19.00	19	41NSM12M
M14	2.00	Coarse	13.30	14.00	9.50	21.67	22.00	22	41NSM14M
M16	2.00	Coarse	15.30	16.00	10.50	23.67	24.00	24	41NS16M
M18	2.50	Coarse	17.66	18.50	13.00	26.16	27.00	27	41NS18M
M20	2.50	Coarse	18.67	20.00	14.00	29.16	30.00	30	41NS20M
M22	2.50	Coarse	20.70	22.00	15.00	31.00	32.00	32	41NS22M
M24	3.00	Coarse	23.15	24.00	15.00	35.16	36.00	36	41NS24M

Size	Thread Pitch (mm)	Thread Type	Overall Nut Height (B) (mm)		Hex Height (H) (mm)	Across Flats (AF) (mm)		Spanner Size (AF) (mm)	sku (qfind)
			Min	Max	Nom	Min	Max		
M27	3.00	Coarse	25.70	27.00	17.00	40.00	41.00	41	41NS27M
M30	3.50	Coarse	28.70	30.00	19.00	45.00	46.00	46	41NS30M

Disclaimer:

Dimensional data and technical information was obtained from publically available sources and not acquired through standard agencies. It has been completed and compiled for reference purposes only; where discrepancies are found they are subject to change without notice. Bolt & Nut Australia makes no warranties or representations regarding the accuracy and validity of the compiled information and data. Contact the relevant standard authorities for accurate and detailed information.

* CAD drawings may not reflect diameter, thread length or overall length.

© Bolt & Nut Australia Pty Ltd. All rights reserved.

Version: 18 Mar 2024